

BE A 70/30 CHURCH

The typical church of Christ is referred to as being an 80/20 church. This generally means that 20% of the members do 80% of the work.

This is sort of a status quo situation which keeps the church operating, but not growing. It is probably characteristic of a lukewarm church.

To understand better what 80/20 means, let's presume that the congregation has 100 members. Presume the "80" do 5 hours of service per year which would relate to a composite workload of 400 hours of work per year. If this is 20%, the total workload must have been 2000 hours for 400 hours to be 20% of that number.

This in turn means that the 20 members do the other 1600 hours of work, or 80 hours each. This relates to approximately 1.6 hours of work per week average throughout the year.

Now let's presume the leadership of the congregation do what it takes to increase the activity to a 70/30 level instead.

If the 70 are simply encouraged to do the minimal work done by the 80 before, it would be 70 members doing the 400 hours of work per year. This would be increase their average workload to 5.71 hours per year instead of 5 hours per year. Better stated, it is 6.6 minutes per week instead of 5.8 minutes per week, on average. That should be achievable.

What is more interesting is that you have moved an extra 10 members into the more committed, more involved level. This does not say that the 30 more involved members simply divide up the work done by the 20 before. The 20 were committed to the cause and remain committed.

All 30 of the more committed members would now average the 80 hours per year for a total of 2400 hours of work done. This means 2400 hours of work from the more committed members and 400 hours of work from the less committed members. This gives a new total of 2800 hours of work to be done rather than the old total of 2000 hours.

This can be 800 hours not dedicated to the ongoing maintenance of the organization, but available to do new and evangelistic things. It is sort of equivalent to saying that you cannot support a missionary because all your income must make the fixed cost payments. When you have more than enough money to make the fixed cost payment, you can do other things such as supporting a missionary.

It can reasonably be said that if your church organization has settled into rut of simply doing what it takes to maintain the status quo, you are not doing your part of the Great Commission. If this is true, wouldn't it be better to lead your congregation on to bigger and better things? As a leader it is not simply better, it is your job.

C	1	2	3	4
1				
2				
3			T	
4				

WHAT THE CHURCH OF CHRIST IS NOT

A local group of Christians who believe that the Bible can be updated by contemporary council decisions.

A church which receives the permission from an earthly headquarters to plant a new congregation..

A church which attempts to duplicate a 19th or 20th century pattern for a church.

A church which believes you can pick and choose what part of the Bible you want to believe and follow only those parts.

A church which believes that we should judge that we are all in a community of believers as long as we say we believe in Jesus, irrespective of what we do and preach. A church which should assure all other that they are saved.

A group who makes decisions based on popularity rather than scriptural basis.

A group which simply skips over Acts 2:38.

A group which finds more convenient ways to simulate baptism.

A group which votes on what it suits them to believe and preach or a group which believes that they are still getting direct revelations from God.

WHAT THE CHURCH OF CHRIST IS

The church of Christ is a local group of Christians which try to speak where the Bible speaks and remain silent where the Bible is silent.

The church of Christ tries to reestablish the first century pattern and teaching of the New Testament era at each location.

The church of Christ tries to reestablish the scriptural organization of the church at each location.

The church of Christ has members who believe they are following the scriptural teachings as best they can.

Church of Christ members believe that we should not judge others' eternal reward, but that it is not reasonable to give comfort to others who follow their own preferences rather than teachings of the Bible.

A non-instrumental body as instruments were available in the first century and not used, and not used for several centuries.

A group who teaches Acts 2:38.

A group which teaches baptism by immersion for the remission of sins as that is what is taught in the Bible.

A group which believes all revelation was given in the first century.

THE CHRISTIAN ARRAY

DEDICATED TO SUSTAINED SCRIPTURAL CHURCH GROWTH IN OUR GENERATION

C	1	2	3	4
1				
2				
3			T	
4				

One day God was looking down at Earth and saw all of the rascally behavior that was going on. So he called one of his angels and sent the angel to Earth for a time.

When he returned, he told God, 'Yes, it is bad on Earth; 95% are misbehaving and only 5% are not.'

God thought for a moment and said, 'Maybe I had better send down a second angel to get another opinion.'

So God called another angel and sent him to Earth for a time.

When the angel returned he went to God and said, 'Yes, it's true. The Earth is in decline; 95% are misbehaving, but 5% are being good.'

God was not pleased. So he decided to e-mail the 5% that were good, because he wanted to encourage them, and give them a little something to help them keep going.

Do you know what the e-mail said?

Okay, I was just wondering, because I didn't get one either.

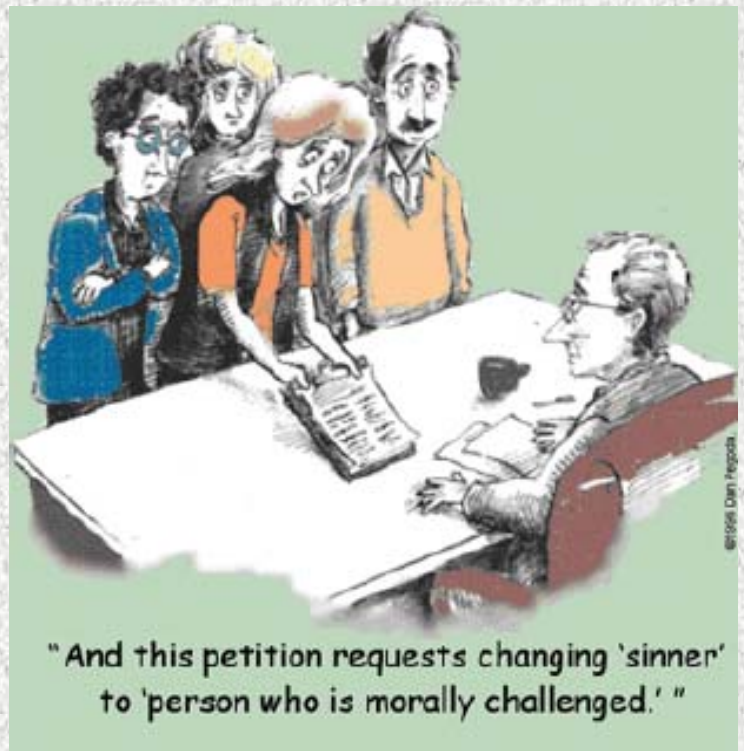

IMPOSSIBLE FOR EVOLUTION: GEORGE

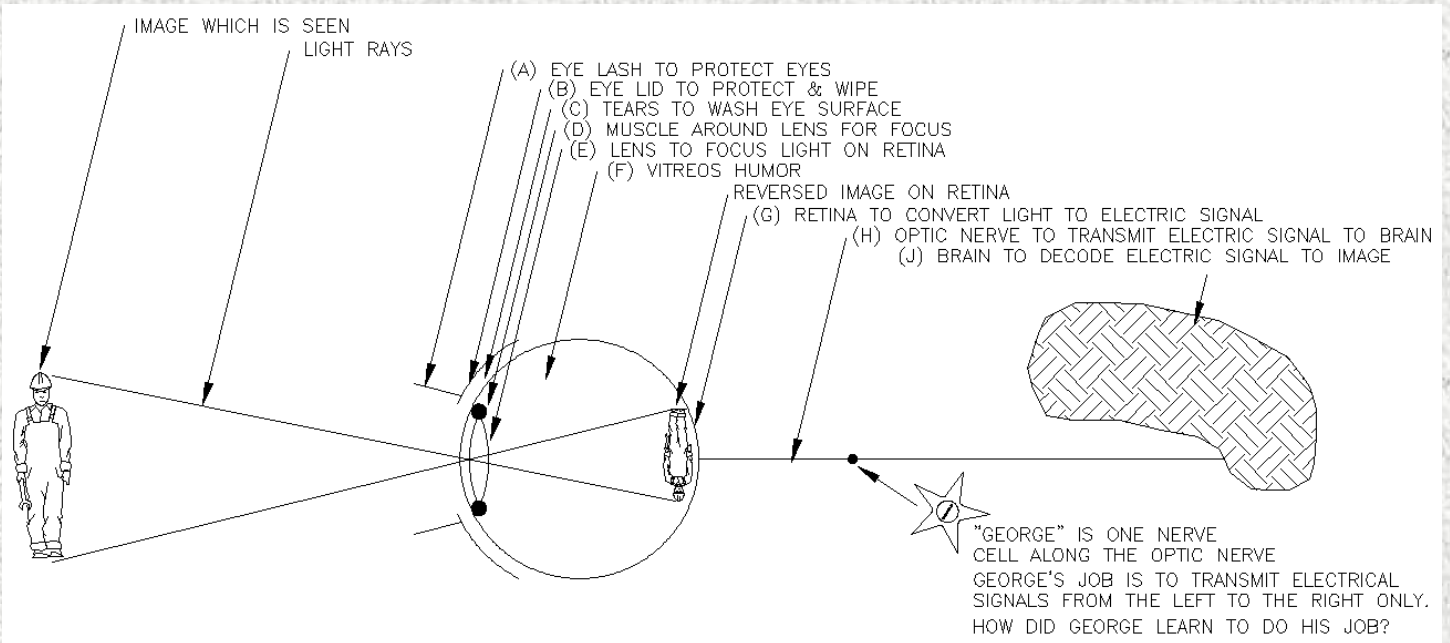

This article is about George, a single cell in the optic nerve of your vision system. He is somewhere in the your optic nerve between your eyeball and your brain. Without knowing why, George must decide to faithfully transmit electric signals from the cell in front of him to the cell behind him so that you can have vision. You are pretty smart and know what to do, can you transmit an electric signal? Imagine that evolutionists think George can do this with no instructions - Impossible.

OTHER JOBS WHICH MUST BE LEARNED BY CELLS FOR VISION TO WORK

BECOME AN EYELASH

BECOME AN EYELID

MUSCLE TO CLOSE AND/OR BLINK AN EYELID

MAKE TEARS

VALVE TO RELEASE TEARS

BECOME A CLEAR LENSE MATERIAL

ARRANGE IN A LENS TO FOCUS

BECOME A MUSCLE AROUND THE LENS TO CAUSE THE FOCUS

TO BECOME A CLEAR LIQUID IN THE VITREOS HUMOR

BECOME SOMETHING WHICH CLEANS THE VITREOS HUMOR

BECOME A LIGHT RECEIVING CELL OF THE RETINA TO MAKE ELECTRICITY

BECOME A FIBER OPTIC CELL TO SEND THE LIGHT SIGNAL TO THE BRAIN

BECOME A BRAIN TO INTERPRET THE ELECTRIC SIGNALS TO BE AN IMAGE (A BIGGIE)

BECOME A NERVE CELL TO SEND A SIGNAL TO THE MUSCLES TO BLINK THE EYELID, FOCUS THE EYE, RELEASE THE TEARS, AND SWIVEL THE EYEBALL.

Is it reasonable to believe this is an accident of evolution? Certainly not. This is a clear proof of God.

CHURCH GROWTH: COMMUNITY OUTREACH

An interesting article in which a University of Houston Vice President concludes that relating to the community is a key to students succeeding. Possibly this is a good component of Christians/churches succeeding also.



COMMUNITY SERVICE IS KEY TO STUDENT SUCCESS

John Antel, provost and senior vice president for academic affairs for UH and senior vice chancellor for academic affairs for the UH System, understands that the fortunes of the university and the Greater Houston community are inextricably linked—with each playing a key role in the other's success.

"We need the city and the community to support us," says Antel. "The community needs us to attract a twenty-first-century workforce and build the cultural capital in the community to attract the best and the brightest. We are partners, and our success is inextricably linked."

Antel, who had been dean of the College of Liberal Arts and Social Sciences since July 2002, assumed his new role as provost and senior vice president/chancellor on February 1.

Antel joined UH as an assistant professor of economics in 1981. He was named an associate professor in 1988 and became a full professor in 1995. Among his numerous leadership roles, he chaired the Department of Economics from 1997 to 2002, and since 2004, has chaired the Undergraduate Enrollment Management Taskforce.

He holds a Ph.D. in economics from the University of California at Los Angeles and a Bachelor of Arts in political science from the University of California at Berkeley. Antel was selected as provost following a national search.

"I am delighted to have Dr. Antel as a key member of my leadership team as we continue to build momentum toward becoming a top-tier research university," says President Renu Khator.

"Dr. Antel is highly respected in the academic world as a researcher and as an administrator, and he has a proven track record of promoting academic excellence and student success."

One key to student success is the hands-on experience gained through work in the community. For example, Antel says, UH's Center for Public History is working on a project about the history of the Third Ward.

"This honors the contributions of this important community and local school history programs, and it helps us do research and train graduate students," he says.

While there are several great ongoing programs in the community, Antel says he would like to see many programs expanded, with more student workers and graduate student trainees doing community-based research and clinical training in a variety of areas.

"While UH does not have significant financial resources to support all community programs, we do have a lot of human capital," he says. "We plan to use our expertise in various areas to reach out and serve this community." ■

C	1	2	3	4
1				
2				
3			T	
4				

CHURCH GROWTH IN OUR GENERATION**JOE ELDER GOES TO JUDGMENT DAY****P 1****BACKGROUND:**

Joe passed away and on his way to judgment day he ran into Jesus. Joe proudly identified himself as an elder of the Park Street Church of Christ from 1989 to 2009, and one of his proudest statistics was that he never missed one of the elder's meetings in 20 years. It was a strong congregation and kept the faith throughout his tenure as an elder. During his tenure, they had actually paid off the mortgage on their building.

Jesus said he was generally aware of that, and more information about the Park Street Church of Christ. Jesus commented that in 1989 there were 400 members, and in 2009 there were 400 members. The service area for the Park Street Church of Christ is generally represented by the 3 adjacent zip codes. These 3 zip codes represented 40,000 citizens in 1980 and 48,800 in 2009, or an average growth rate of 1%. This means that if the members moving into your area had simply identified with your congregation you would have seen a 1% growth. This growth would have been in Park City Church of Christ as there were no church splits, mergers, or plantings during these 20 years.

Jesus asked Joe if it would be reasonable to expect each of the 2 paid preachers to convert one person per year, each of your six elders to convert one person at least every other year, each of your deacons to convert at least one person every 3 years, and your other members to average converting one person every 25 years. Joe said of course that would be reasonable to expect. Jesus said that would work out to a minimum 6% annual growth rate (turns out Jesus is good at math in his head).

QUESTION:

Jesus asked Joe, if you understand what is said above to be reasonable, then you would agree that it was reasonable for me to expect a 1% plus 6% or 7% growth rate from the Park City Church of Christ. A 7% growth rate in the first year would be 28 members or an average attendance growth from 400 to 428. Compounded for 20 years this would be an average church attendance in the 20th year of 1547 members. As shepherd of the flock at Park Street Church of Christ, I think we can reasonably say that I expected 1547 members. Not only do I not see 1547 souls, but when you took your place as a leader of this congregation 400/40,000 or 1 in 100 citizens were a member of the church. After 20 years of your leadership only 400 in 48,800 or 1 in 122 citizens were a member of the church.

My question to you Joe is this: My Gospel is powerful and you were in a leadership position to direct the flock in your area. When your leadership style did not produce results in years 1, 2, 3, 4, 5, 6, 7, 8, 9, and 10, how many years did you plan to keep on doing the same things which did not produce fruits? Where are the additional 1147 souls which you should have communicated the Gospel to?

C	1	2	3	4
1				
2				
3			T	
4				

CHURCH GROWTH IN OUR GENERATION

JOE ELDER GOES TO JUDGMENT DAY

P 2

THE RESPONSES OF JOE ELDER (TAKE YOUR PICK):

1. You are simply talking about numbers and trying to keep score. We were focused on the fellowship of the congregation and the worship of your holy name. **Jesus said – Did you read Matthew 25:24-30?**
2. It was not socially acceptable to imply others were not saved during this time so we switched our theme more to love and friendship so people would feel at home at our services. We were doing good just to hold our own. **Jesus said evangelism was not particularly acceptable in the first century either, in fact they crucified me. Did you read Matthew 25:24-30?**
3. We told members to do things and appointed committees and ministries. The deacons and members simply would not cooperate and do anything. **Jesus said that Park Street was clearly a ten talent church and the talents were not being used. You used a 19th century organizational plan to manage a 21st century church. I gave you plenty of years to learn the difference. Did you read Matthew 25:24-30?**
4. The ultimate answer: None of the other congregations were growing either. **Jesus said I find it interesting that the former elders from the smaller congregations around Park Street usually justify their non-evangelism because Park Street is not growing either. Did you read Matthew 25:24-30?**

POSTSCRIPT:

If you think this article is intended to irritate elders, you are perceptive. If the church is to survive and grow, we must keep the gospel and make changes which actually work. Elders are called shepherds and members are called a flock or sheep. If the congregation is not growing the shepherds have the power to say that it is the fault of the sheep. It is probably more reasonable to say that the responsibility for the results is in proportion to the authority to do something about it. It would be unscriptural for the sheep to take on the role of being shepherds. The sheep will go to judgment day also, but their judgment will be different.

C	1	2	3	4
1				
2				
3			T	
4				

NEW SPANISH WORK IN SPRING BRANCH IN WEST HOUSTON

As of the first of the year, Jim Culpepper began a new work in the Spring Branch area which is focused on the Spanish speaking brethren (and future brethren and sisters). If you might be interested in helping in this work, contact Jim at Jim L. Culpepper & Associates, P. C., 9821 Katy Freeway, Suite 110, Houston, Texas 77024-1208, Telephone: 713-463-6300, Fax: 713-463-6301, or jim@culpepperlaw.com. Jim has been a leader in this work for many years and should be commended and supported in his new challenge.

FILL-IN PREACHERS

We are starting a pilot program to coordinate fill-in preachers for various congregations in the greater Houston Area. The presumption is that there are some larger congregations who have more men willing to present an occasional sermon than opportunities exist, and there are some smaller congregations where more opportunities exist than speakers.

Visit thearray.org and click on **FILL-IN PREACHERS** to see if any of the speakers / topics are interesting to you, or if you would like to add a topic to the list.

If you want to add a topic, you need to indicate your name, home congregation, phone number, and 1 to 4 topics. Each title and description of a topic should be 15-30 words. Send the list to info@thearray.org.

ARTICLES NEEDED

Whereas we are interested in articles which support the themes of this newsletter and articles of general interest, we want to request articles which oppose these viewpoints. It is educational to be exposed to and understand various points of view.

We would like to specifically invite an article which justifies the non-growth of a congregation from anyone who does not believe that church growth is God's plan.

SUSTAINED SCRIPTURAL CHURCH GROWTH CONFERENCE

We are considering sponsoring a conference on sustained scriptural church growth in the greater Houston area. If you would like to speak at such a conference, would attend, or be involved in any other way, let us know at info@thearray.com.

The conference would not address doing the same things to continue to not grow. It would be focused on what we can do to remain scriptural and grow.



MONEY PAGE

GUARANTEED CHURCH GROWTH

If your congregation does the following, BCE Publications guarantees that it will grow.

Poll your congregation three times at 6 months intervals with the following results:

- 50% of the members know who their elder is
- 50% of the members will say that a minister is their friend
- 50% of the members will say that they are uplifted by the song services
- 50% of the men will say that their input is considered before physical decisions are made
- 50% of the members will say they are an important part of the work
- 50% of the members will say they are aware of the goals of the congregation
- 50% of the members will say that they know what their part is in achieving your goals

GUARANTEE: For the first congregation which does this and does not grow by at least 10%, we will send \$1000 to the church related children's home of your choice in your name.

I have never met a person who said that if they did this their church would not grow. If your congregation is not growing, what have you got to lose? (Offer made since 2001)

IMPOSSIBLE FOR EVOLUTION?

We will offer \$100 to the first person who can explain how we could have violated the first law of thermodynamics and have come into existence without God.

We will offer \$100 to the first person who can explain how we could have violated the second law of thermodynamics and have existed forever without God.

(Offer first posted 8/08)

IMPOSSIBLE FOR EVOLUTION!

This publication continues (since 1991) to make a standing offer of \$100 to the first person who can give any reason (1 or more) as to why atheistic evolution is a better explanation for the universe and/or life than creation by God, The Father of Adam, Abraham, and Jesus; as revealed in the Bible.

We will also give you \$100 if we cannot give you 12 reasons why atheistic evolution is impossible as an explanation for our existence.

We will discuss this any place, any time, and in any forum.

(This offer has been made repeatedly since June of 1991 with no takers)

C	1	2	3	4
1				
2				
3			T	
4				

AREA WIDE ACTIVITIES

AREA WIDE WORSHIP SERVICE

Fifth Ward Church of Christ and Memorial Church of Christ have been exchanging annual visits to each other's congregations for Sunday evening services. It is an activity well received by all members, and has included a meal prepared by the hosting congregation.

Discussions are underway between the congregations to sponsor an AREA WIDE WORSHIP SERVICE, potentially once a quarter. A possible venue could be the 5000 seat Don Coleman Basketball stadium on Dairy Ashford in west Houston. Hosting a meal is probably not practical. If you have ideas on how to implement this, want to help implement this, would like to attend, or have other comments, send to info@thearray.org and we will forward them to those having the discussions.

YAHOO GROUP

HoustonCofC is a Yahoo group hosted by Steve Sandifer [steve.sandifer@sbcglobal.net] for the purpose of communicating Houston area news among the brethren. It is open to any member of the church at no cost.

The Christian Array Newsletter

This newsletter will be sent to members of the church on a monthly basis as an attempt to promote area wide activities and church growth. If you do not want to receive this newsletter, send an e-mail to info@thearray.org and it will be stopped.

If you know of anyone who would like to receive this newsletter, send their e-mail addresses to info@thearray.org. All past copies of the newsletter can be found on the website "thearray.org".

E-MAIL ADDRESSES

A goal of this newsletter is to develop a mailing list of as many members of the church as possible and to communicate church related information to as many members as possible. In that light, we would appreciate:

1. Your forwarding the church member e-mail addresses which you have.
2. Sending the directory of the congregation you attend or any other directories which you might have.
3. Give us an idea of how to collect church member e-mail addresses.

This information will not be sold or used for any purpose not mentioned herein.

The Christian Array is dedicated to support the sustained scriptural growth of the churches of Christ. It is published by BCE Publications, a 501(c)(3) organization with Benton F. Baugh, Ph.D., P.E. as editor. BCE is solely responsible for the content. Any announcements, requests for publication, or comments should be e-mailed to info@thearray.org.